

Specification-grade landscape lighting, wet-location luminaire for uplighting or downlighting applications. Can be utilized for ground mounted, tree mounted or surface mounted installations.

- Machined 6061-T6 copper-free aluminum. Aluminum components are black anodized, then a polyester powder coat finish is applied.
- Seven standard TGIC powder coat finishes and clear anodized finish available.
- Remote transformer required.
- Stainless steel hardware.
- Threaded cap and body provide for 'toolless' lamping of fixture.
- 2ft. 18/2 LV wire leads.
- 1" regressed lens cap for glare control holds 3 lens accessories.
- Clear tempered glass lens, glued in.
- High-temperature silicone O-ring seal used to seal the cap against the body.
- Molded silicone wire pass-thru attached to socket wire prevents wicking and water leaking into the lamp compartment.
- Listed for wet location use.
- Warranty: 10 Years.

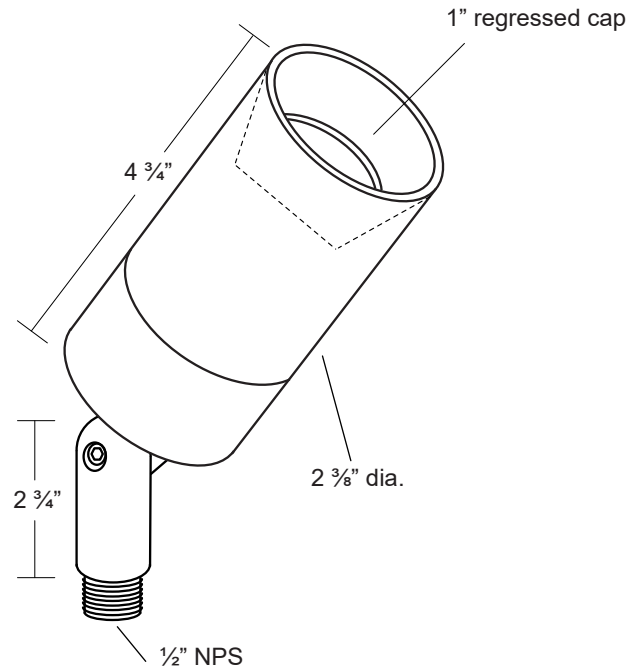

Specifications

MODEL:	FA - 9	LAMPING:	MR16 Halogen (order separately) 50W Maximum (order separately) 8W LED (order separately)
MATERIAL:	6061-T6 Aluminum		
VOLTAGE:	12V		
WATTAGE:	50 Watt		
SOCKET:	GY-6.35 Bi-pin porcelain socket rated 600V, 250°C 18 ga, Teflon® coated leads.		

Ordering Logic:

MODEL	METAL	FINISH	
FA - 9	A - Aluminum	BK - Black BZ - Bronze WT - White BG - Beige	BKT - Black Texture BZT - Bronze Texture SL - Silver AC - Aged Copper

ORDERING EXAMPLE: FA - 9 - A - BZT

Excelsior Lighting, Inc.

PROJECT:

TYPE: