

Specification-grade landscape lighting, wet-location luminaire for path or garden lighting applications.

- Machined 6061-T6 copper-free aluminum. Aluminum components are black anodized, then a polyester powder coat finish is applied.
- Seven standard TGIC powder coat finishes and clear anodized finish available.
- Integral LED Module: 2W, 4W, 6W, 9W ( 12W startup draw )
- Available in 2700K, 3000K, 4000K.
- Remote transformer required.
- Stainless steel hardware.
- 6 feet of 18/2 low voltage cable supplied.
- Three cap styles from which to choose.
- Stems lengths of 9"- 36" available.
- Adjustable or fixed mounting. (see MT-1 and MT-2)
- Clear tempered glass lens, glued in.
- High-temperature silicone O-ring seals are used to seal the cap against the body.
- Molded silicone wire pass-thru is attached to socket wire prevents wicking and water leaking into the lamp compartment.
- Listed for wet location use.
- Warranty: 10 Years.

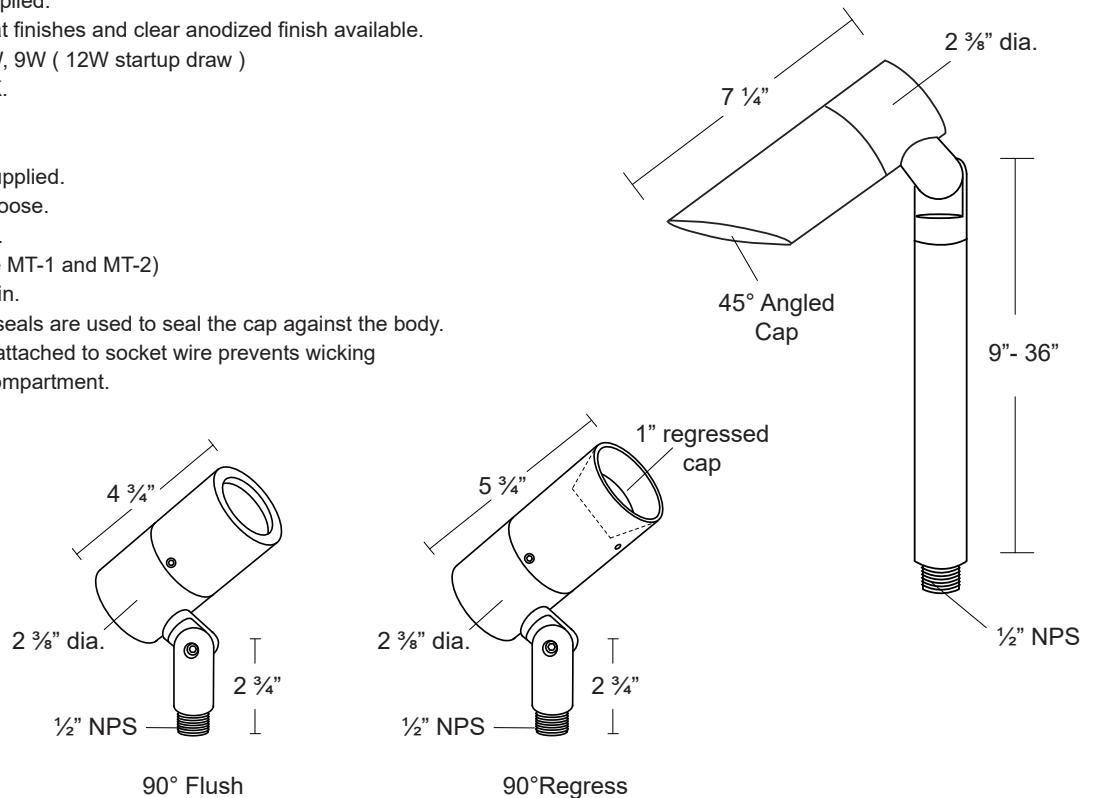

**Specifications:**

MODEL: PL-7L  
 MATERIAL: 6061-T6 Aluminum  
 VOLTAGE: 10.8-13.2V  
 WATTAGE: 2W, 4W, 6W, 9W  
 SOCKET: GY 6.35 Bi-pin porcelain socket rated 600V, 250°C 18 ga, Teflon ® coated leads.

LAMPING: 9W LED Module ( 12W startup draw )

Wattage	2700k	3000K	4000K
2W	165 lms	190 lms	210 lms
4W	345 lms.	360 lms.	385 lms
6W	515 lms.	530 lms.	590 lms
9W	720 lms.	800 lms.	860 lms

**Ordering Logic:**

MODEL	METAL	CAP	STEM LENGTH		FINISH	
PL - 7L	A - Aluminum	1 - Flush	9 - 9"	24 - 24"	BK - Black	BKT - Black Texture
		2 - Regress	12 - 12"	30 - 30"	BZ - Bronze	BZT - Bronze Texture
		3 - 45 Degree	18 - 18"	36 - 36"	WT - White	SL - Silver
					BG - Beige	AC - Aged Copper

ORDERING EXAMPLE: PL - 7L - A - 1 - 12 - BZT - 52\*

\*See Terralux Module sheet to select module type to be installed

Excelsior Lighting, Inc.

PROJECT

TYPE

9W MULTI-LEVEL - 2W, 4W, 6W, 9W (165-860 Lumens)



- Equivalent to MR16 20W/35W/50W/75W Halogen (equivalent CBCP)
- Four light levels, 2700K, 3000K, or 4000K
- 10.8-13.2V AC/DC
- 12W startup draw
- Interchangeable lenses: 15°, 30°, 45°, 60°
- Superior Light Output and thermal performance compared to LED Replacement Lamps
- Compatible with low-voltage magnetic transformers
- L70=60,000 hours
- 3 Year warranty
- FCC Compliant
- RoHS Compliant
- Pb Free
- Field Replaceable

#	Specifications	Lumens
50	2W - 9W, 2700K, 15°	165-720
51	2W - 9W, 2700K, 30°	165-720
52	2W - 9W, 2700K, 45°	165-720
60	2W - 9W, 2700K, 60°	165-720
53	2W - 9W, 3000K, 15°	190-800
54	2W - 9W, 3000K, 30°	190-800
55	2W - 9W, 3000K, 45°	190-800
61	2W - 9W, 3000K, 60°	190-800
62	2W - 9W, 4000K, 15°	210-860
63	2W - 9W, 4000K, 30°	210-860
64	2W - 9W, 4000K, 45°	210-860
65	2W - 9W, 4000K, 60°	210-860

Wattage	2700k	3000K	4000K
2W	165 lms	190 lms	210 lms
4W	345 lms.	360 lms.	385 lms
6W	515 lms.	530 lms.	590 lms
9W	720 lms.	800 lms.	860 lms

LENSES INCLUDED

15°



45°



30°



60°

