

Specification-grade landscape lighting, wet-location luminaire for up lighting or down lighting applications. Can be utilized for ground mounted, tree mounted or surface mounted installations.

- Machined 6061-T6 copper-free aluminum. Aluminum components are black anodized, then a polyester powder coat finish is applied.
- Seven standard TGIC powder coat finishes and clear anodized finish available.
- Stainless steel hardware.
- 10" 18ga. Teflon coated wire leads.
- Medium base ceramic socket
- 1" regressed lens cap holds 2 lens accessories.
- Mount not included.
- Clear tempered glass lens, glued in.
- High-temperature silicone O-ring seal used to seal the cap against the body.
- Listed for wet location use.
- Warranty: 10 Years.

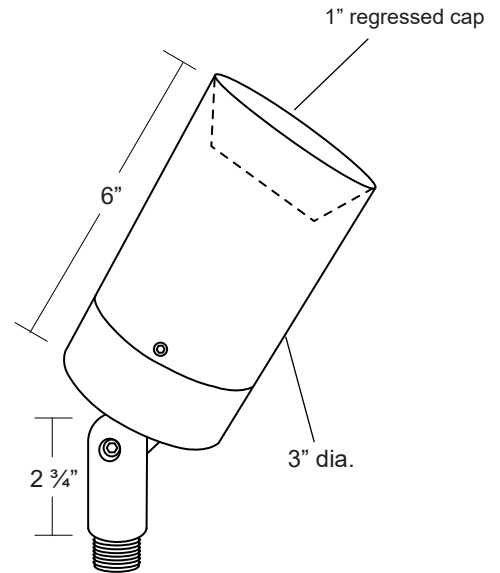

Specifications

MODEL:	FA - 29	LAMPING:	PAR20 Halogen, 50W Maximum (order separately) 11W LED (order separately)
MATERIAL:	6061-T6 Aluminum		
VOLTAGE:	120V		
WATTAGE:	50 Watt		
SOCKET:	Medium base ceramic socket rated 600V, 250°C 18 ga, Teflon® coated leads.		

Ordering Logic:

MODEL	METAL	FINISH	
FA - 29	A - Aluminum	BK - Black	BKT - Black Texture
		BZ - Bronze	BZT - Bronze Texture
		WT - White	SL - Silver
		BG - Beige	AC - Aged Copper

ORDERING EXAMPLE: FA - 29 - A - BK

Excelsior Lighting, Inc.

PROJECT:

TYPE: