

Specification-grade landscape lighting, wet-location luminaire for step lighting or path lighting applications.

- Available in 2W - 160 lumens, 4W - 320 lumens.
- Kelvin options: 2700K, 3000K, 4000K available.
- Machined aluminum, available in seven standard TGIC powder coat finishes and clear anodized finish.
- Machined brass available in two finishes.
- Remote transformer required.
- Stainless steel hardware.
- Clear lens.
- Single gang junction box design.
- High-temperature silicone O-ring seal used to seal the cap against the body.
- Molded silicone wire pass-thru attached to socket wire prevents wicking and water leaking into the lamp compartment.
- Listed for wet location use.
- Warranty: Aluminum: 10 Years, Brass: 25 Years.

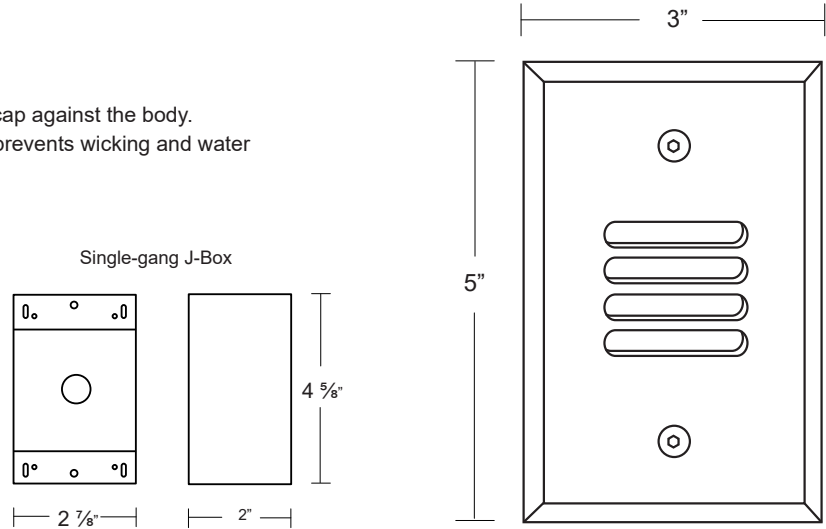

Specifications

MODEL: ST-8L

LAMPING: 1 COB LED (2W/4W) (160 lms./ 320 lms.)

MATERIAL: Aluminum or Brass

VOLTAGE: 12VDC

WATTAGE: 2 Watt, 4 Watt

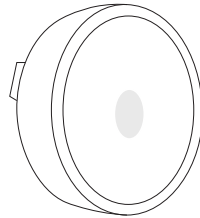

Replaceable LED Module:

Our waterproof LED module is available in 2W and 4W versions. It is field replaceable. Available in three Kelvin choices: 2700K, 3000K and 4000K.

Ordering Logic:

MODEL	METAL	WATTAGE	KELVIN	FINISH	
ST - 8L	A - Aluminum	2 - 2 Watt	27 - 2700K	BK - Black	BKT - Black Texture
	B - Brass	4 - 4 Watt	30 - 3000K 40 - 4000K	BZ - Bronze WT - White BG - Beige NT - Natural	BZT - Bronze Texture SL - Silver AC - Aged Copper DB - Dark Brass

ORDERING EXAMPLE: ST - 8L - A - 2 - 27 - BK

Excelsior Lighting, Inc.

PROJECT

TYPE