

Specification-grade landscape lighting, wet-location luminaire for path or garden lighting applications.

- Machined 6061-T6 copper-free aluminum. Aluminum components are black anodized, then a polyester powder coat finish is applied.
- Seven standard TGIC powder coat finishes and clear anodized finish available.
- Stainless steel hardware.
- Conduit mounting stake included
- Three cap styles from which to choose.
- Stems lengths of 12"- 48" available.
- Clear tempered glass lens, glued in.
- High-temperature silicone O-ring seals are used to seal the cap against the body.
- Molded silicone wire pass-thru is attached to socket wire prevents wicking and water leaking into the lamp compartment.
- Listed for wet location use.
- Warranty: 10 Years.

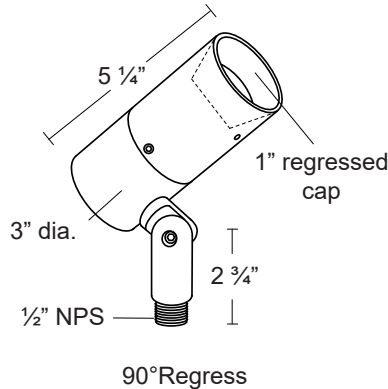
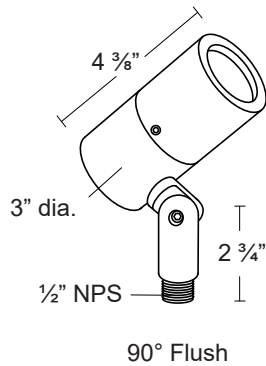
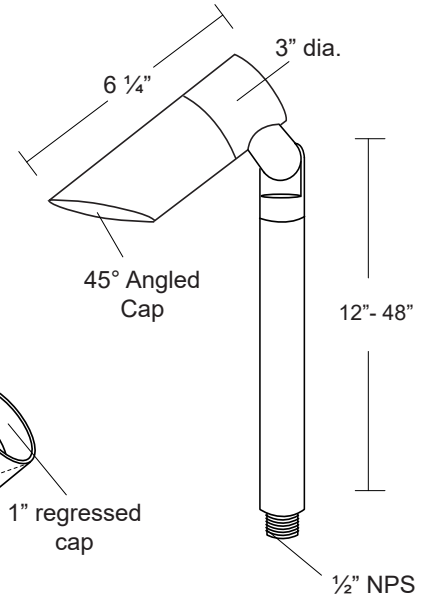

Specifications

MODEL: PL - 27  
 MATERIAL: 6061-T6 Aluminum  
 VOLTAGE: 120V  
 WATTAGE: 50 Watt  
 SOCKET: GU 10 porcelain socket rated 600V, 250°C 18 ga, Teflon® coated leads.

LAMPING: MR16 Halogen, 50W Maximum (order separately) 9W LED (order separately)

Other Mount Options:

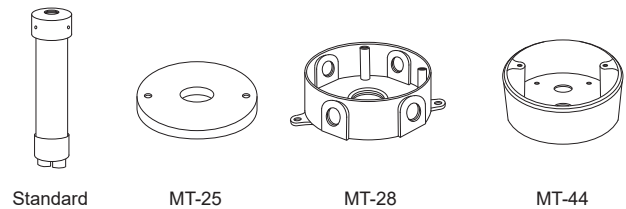

Ordering Logic:

MODEL	METAL	CAP	MOUNTINGS	STEM LENGTH	FINISH
PL - 27	A - Aluminum	1 - Flush 2 - Regress 3 - 45 Degree	1 - Conduit Stake(Incl) 2 - MT-25 3 - MT-28 4 - MT-44	12 - 12" 36 - 36" 18 - 18" 42 - 42" 24 - 24" 48 - 48" 30 - 30"	BK - Black BKT - Black Texture BZ - Bronze BZT - Bronze Texture WT - White SL - Silver BG - Beige AC - Aged Copper

ORDERING EXAMPLE: PL - 27 - A - 1 - 1 - 24 - BK

Excelsior Lighting, Inc.

PROJECT

TYPE