

Specification-grade well light, wet-location luminaire for uplighting applications.

- Cast aluminum. Seven standard TGIC powder coat finishes and two bronze finishes.
- Remote transformer required.
- GY 6.35 bi pin porcelain socket.
- IP 68 rated.
- 15 degrees of aiming adjustment.
- Machined aluminum lamp holder.
- Tempered glass lens.
- Holds 3 lens accessories.
- Suitable for drive-over installations.
- 6 feet of 16/2 low voltage cable supplied.
- Warranty: 25 Years.

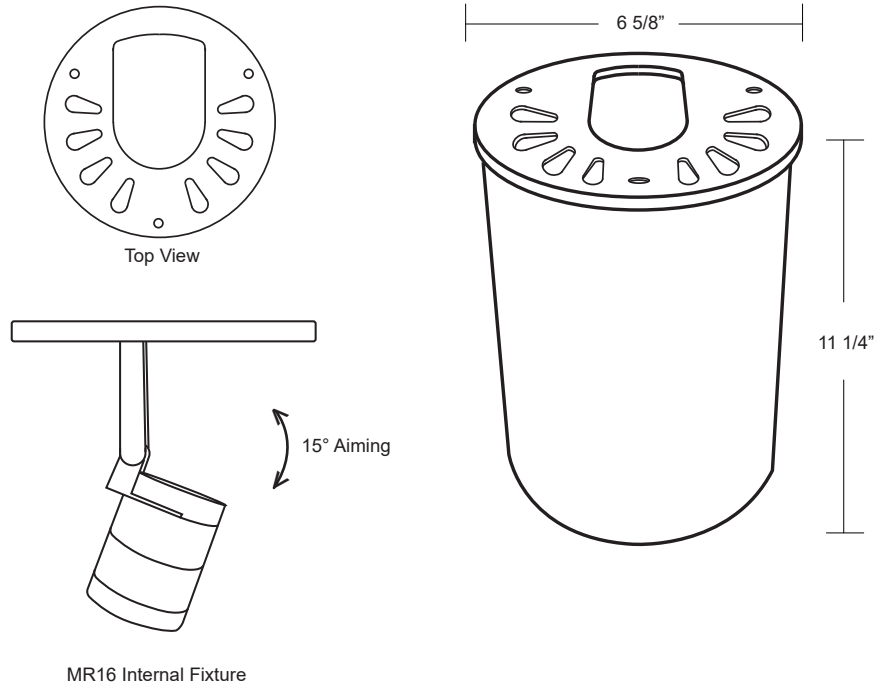

Specifications:

MODEL:	IN-10	LAMPING:	MR16 Halogen, 35W Maximum (order separately) 8W LED (order separately)
MATERIAL:	Cast Aluminum		
VOLTAGE:	12V		
WATTAGE:	35 Watt		
SOCKET:	GY-6.35 Bi-pin porcelain socket rated 600V, 250°C 18 ga, Teflon® coated leads.		

Ordering Logic:

MODEL	METAL	FIXTURE REGRESS	FINISH	
IN - 10	A - Aluminum	1 - 1 3/4" 2 - 3" (standard)	BK- Black BZ - Bronze WT - White BG - Beige NT - Natural	BKT - Black Texture BZT- Bronze Texture SL - Silver AC - Aged Copper DB - Dark Bronze

ORDERING EXAMPLE: IN - 10 - A - 1 - BK

Excelsior Lighting, Inc.

PROJECT

TYPE