

Heavy-duty, laser cut stainless steel ground spike for ground-mounting low voltage luminaires.

- Stainless steel ground spike.
- 3/16" thick, 304 grade stainless steel .
- Laser cut design for strength.
- Spike lengths available in 6" or 10".
- 4 1/2" diameter top plate.
- 1/2" NPS mount threads.
- No welds to break.
- Bronze powder coat finish (standard).
- Optional jam nut with black anodized finish.
- Jam nut locks luminaire against mount used.
- Jam nut provides rotational aiming of fixture.
- Warranty: 25 years.

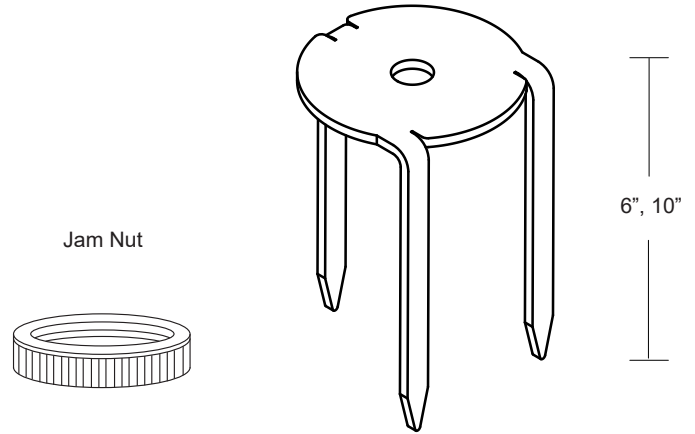

Specifications

MODEL: MT-6

MOUNTING: 1/2" NPS

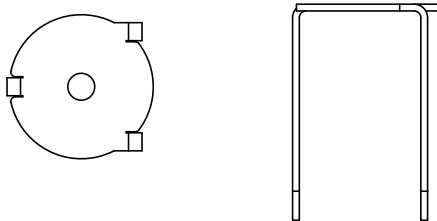

Specifications and dimensions are subject to change without notice. See website for most current information.

Ordering Logic:

MODEL	SPIKE LENGTH	JAM NUT	FINISHES	
MT - 6	6 - 6" 10 - 10"	0 - None 1 - One	BK - Black BZ - Bronze WT - White BG - Beige	BKT - Black Texture BZT - Bronze Texture SL - Silver AC - Aged Copper

ORDERING EXAMPLE: MT - 6 - 10 - 1 - BK

Excelsior Lighting, Inc.

PROJECT

TYPE