

Specification-grade landscape lighting, wet-location luminaire for down lighting applications. Can be utilized for junction box or surface mounted installations.

- Machined 6061-T6 copper-free aluminum. Aluminum components are black anodized, then a polyester powder coat finish is applied.
- Seven standard TGIC powder coat finishes and clear anodized finish available.
- Adjustable LED Module: 2W, 4W, 6W, 9W. (12W startup draw)
- CRI = 85
- Available in 2700K, 3000K, 4000K.
- Remote magnetic transformer required.
- Not compatible with electronic transformers.
- Stainless steel hardware.
- 10" 18ga. Teflon coated wire leads.
- 1/2" NPS Mount Threads (Mount not included)
- High-temperature silicone O-ring seal used to seal the cap against the body.
- Molded silicone wire pass-thru attached to socket wire prevents wicking and water leaking into the lamp compartment.
- Tempered clear glass lens.
- 30° angled lens cap holds 1 lens accessory.
- Listed for wet location use.
- Warranty: 10 Years.

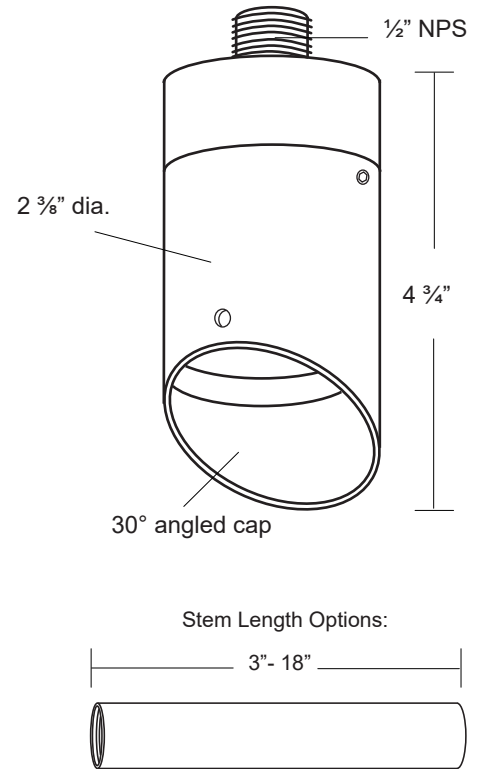

Mounting Plate Options:

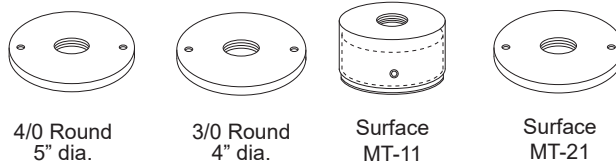

Specifications

MODEL: DL - 13L
 MATERIAL: 6061-T6 Aluminum
 VOLTAGE: 12VAC/DC
 WATTAGE: 2W, 4W, 6W, 9W

LAMPING: 9W LED Module (12W startup draw)

Wattage	2700k	3000K	4000K
2W	165 lms	190 lms	210 lms
4W	345 lms.	360 lms.	385 lms
6W	515 lms.	530 lms.	590 lms
9W	720 lms.	800 lms.	860 lms

Ordering Logic:

MODEL	METAL	MOUNTING PLATE	STEM LENGTH	FINISH
DL - 13L	A - Aluminum	1 - 4/0 Round 2 - 3/0 Round 3 - Surface MT-11 4 - Surface MT-21	0 - None 9 - 9" 3 - 3" 12 - 12" 6 - 6" 18 - 18"	BK - Black BZ - Bronze WT - White BG - Beige BKT - Black Texture BZT - Bronze Texture SL - Silver AC - Aged Copper

ORDERING EXAMPLE: DL - 13L - A - 1 - 0 - BK - 55*

*See Module sheet to select module type to be installed

Excelsior Lighting, Inc.

PROJECT

TYPE

9W MULTI-LEVEL - 2W, 4W, 6W, 9W (165-860 Lumens)



- Equivalent to MR16 20W/35W/50W/75W Halogen (equivalent CBCP)
- Four light levels, 2700K, 3000K, or 4000K
- 10.8-13.2V AC/DC
- 12W startup draw
- Interchangeable lenses: 15°, 30°, 45°, 60°
- Superior Light Output and thermal performance compared to LED Replacement Lamps
- Compatible with low-voltage magnetic transformers
- L70=60,000 hours
- 3 Year warranty
- FCC Compliant
- RoHS Compliant
- Pb Free
- Field Replaceable

#	Specifications	Lumens
50	2W - 9W, 2700K, 15°	165-720
51	2W - 9W, 2700K, 30°	165-720
52	2W - 9W, 2700K, 45°	165-720
60	2W - 9W, 2700K, 60°	165-720
53	2W - 9W, 3000K, 15°	190-800
54	2W - 9W, 3000K, 30°	190-800
55	2W - 9W, 3000K, 45°	190-800
61	2W - 9W, 3000K, 60°	190-800
62	2W - 9W, 4000K, 15°	210-860
63	2W - 9W, 4000K, 30°	210-860
64	2W - 9W, 4000K, 45°	210-860
65	2W - 9W, 4000K, 60°	210-860

Wattage	2700k	3000K	4000K
2W	165 lms	190 lms	210 lms
4W	345 lms.	360 lms.	385 lms
6W	515 lms.	530 lms.	590 lms
9W	720 lms.	800 lms.	860 lms

LENSES INCLUDED

15°



45°



30°



60°

